

TECHNICAL SPECIFICATION:-

- CAPACITY - 1000 KGS.**
- MIN. HIEGHT - 500 MM**
- MAX HIEGHT - 1636 MM**
- MANUAL PUMP**

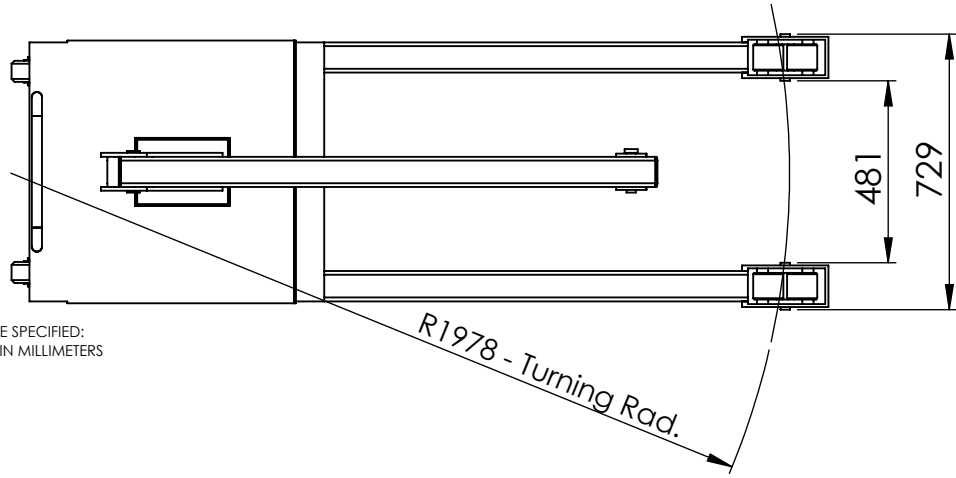
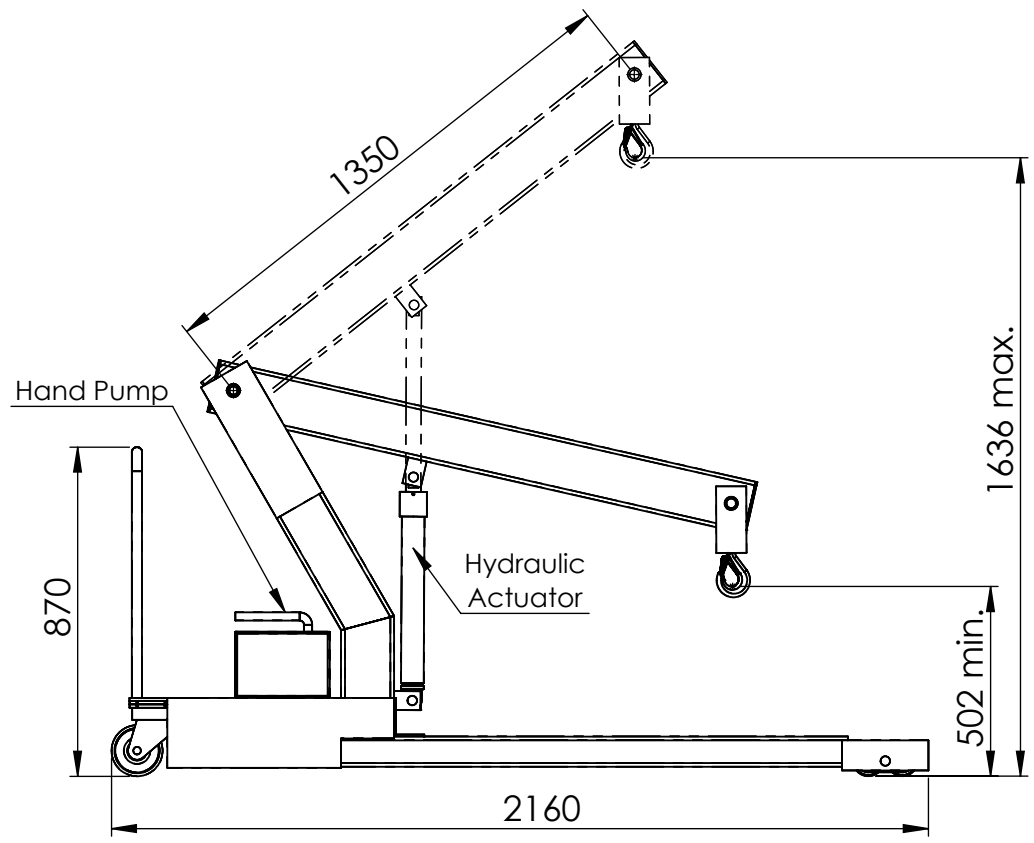
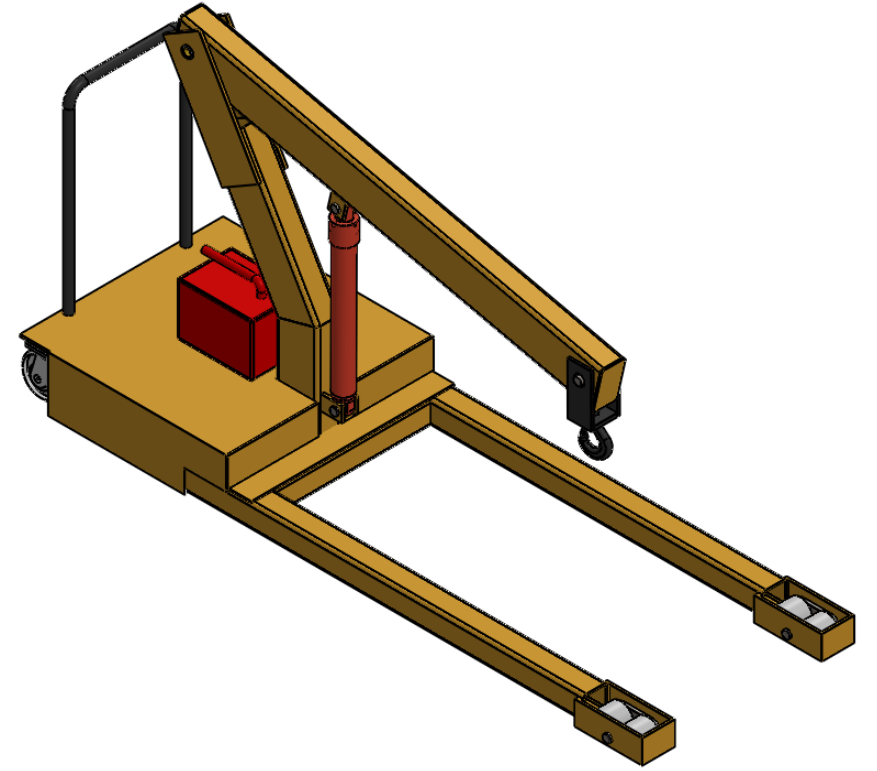

UNLESS OTHERWISE SPECIFIED:
 DIMENSIONS ARE IN MILLIMETERS
 SURFACE FINISH:
 TOLERANCES:
 LINEAR:
 ANGULAR:

DEBURR AND BREAK SHARP EDGES	AVCON SYSTEMS	
	306, Solanki Apartments, Solanki Co-Op Hsg, Louiswadi , Thane - 400604	
Drawn : Krishna	TITLE:	Floor Crane
Checked: K.T		
Approved :	DWG NO.	1471
WEIGHT:		
SCALE:1:20	SHEET 1 OF 1	